

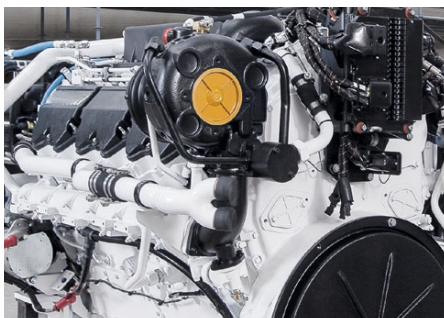

MANN+HUMMEL
Fuel Filters

MANN+HUMMEL

Leadership in Filtration

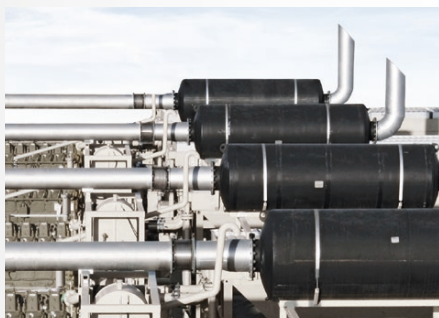

MANN+HUMMEL is a leading global expert for filtration solutions. The company group with its headquarters in Ludwigsburg, Germany, develops solutions for motor cars, industrial applications, clean air in interior spaces and the sustainable use of water. In 2017 more than 20,000 employees were employed by the group at more than 80 locations. The products manufactured by the group include air cleaner systems, intake manifold systems, liquid filter systems, plastic components, filter media, cabin air filters, industrial filters and membrane filters.

A key area are high quality filtration products for vehicles, engines and industrial applications. The original equipment business with leading global vehicle, machine and plant manufacturers forms the basis for the quality and performance of our products. Replacement parts are sold under numerous world-famous customer brands as well as under the company's own MANN-FILTER brand.

The product range described in this catalog was developed especially for special customer requirements in the areas of off-highway, vehicle and engine engineering, compressed air and vacuum technology, machinery and mechanical engineering. MANN+HUMMEL offers high performance products for these and other industrial fields in the area of filtration and separation of air, gases and liquids.

Important note for our customers

We are continually further developing our product range in order to make our high performance and economical filtration products even better. For this reason we expressly reserve the right to change our products and delivery program after this catalog has been published. This includes technical changes and also the discontinuation of products, in particular for older products. Information on changes and general availability can be obtained from your MANN+HUMMEL contact person.

Fuel filters

Contents

FUEL FILTERS IN GENERAL	PAGE 4
Fuel filters – Multiple solutions	Page 4
Fuel filters in the low-pressure circuit	Page 5
Multigrade F media technology	Page 6
Water separation media technology	Page 7
MANN+HUMMEL PRELINE PREFILTERS	PAGE 8
Filter systems	Page 10
PreLine 50	Page 10
PreLine 100 and 150	Page 11
PreLine 150	Page 12
PreLine 250	Page 13
PreLine 270	Page 14
PreLine 420	Page 15
PreLine 601	Page 16
Filter heads – Selection	Page 18
Filter heads and prefilters	Page 19
up to 150 l/h	Page 19
up to 250 l/h	Page 20
up to 1,200 l/h	Page 22
MANN+HUMMEL MAIN FILTERS	PAGE 24
up to 600 l/h	Page 27
up to 1,600 l/h	Page 28
up to 2,800 l/h	Page 30
TANK TWO-WAY VENTILATION AIR CLEANERS	PAGE 32
INLINE FILTERS	PAGE 34
ACCESSORIES	PAGE 36
PreLine water sensors	Page 37
Bowl and water discharge	Page 38
LOCATIONS AND CONTACT PERSONS	PAGE 40

Fuel filters

Multiple solutions

Whether proven standard systems or individually developed filter systems, MANN+HUMMEL offers a wide range of solutions. Depending on requirements and targets, standardized products or individually tailored systems can be obtained from MANN+HUMMEL.



STANDARD FILTER SYSTEMS

Our proven filter systems have been used in numerous field applications for many years. The long-term and continual development of MANN+HUMMEL filtration solutions has enabled us to maintain our high quality standards. In this process, a risk management system helps us to identify risks and to minimize these early on. The development time and budget as well as the required time for tool design are reduced to a minimum. This enables the quick deployment of different filter systems with a range of performance levels.

CUSTOMIZED SOLUTIONS

There is not always a suitable standard solution for every application. Objectives such as functional integration and better exploitation of installation space lead to higher requirements for filtration performance in terms of separation efficiency and service life and this in turn requires special solutions. MANN+HUMMEL offers customized filter systems manufactured according to our high quality standards which are tailored to your specific needs.

Fuel filters in the low-pressure circuit

Modern common rail systems place the highest requirements on the systems used for fuel preparation. Injection pressures in the range of 2,500 bar and above and the resulting clearances and tolerances in the injectors make high efficient filter systems necessary. In addition, there are the required service life and increasing demands on the service intervals, which have established themselves in practice as coordinated system solutions.

Main filters fitted on the pressure side, such as the MANN+HUMMEL WDK or WK series are usually mounted between the pre-feed pump and the high pressure pump in the low pressure circuit. A separation efficiency of at least 98.6 percent is required in order to achieve the specification of the purity class upstream of the high pressure pump. Depending on the requirement of the pre-feed pump, prefilters fitted on the suction side, such as the MANN+HUMMEL PreLine, separate

up to 99.9 percent of particles in the range of 10 μm to 30 μm . In addition, the prefilter systems achieve the required water separation efficiency of at least 93 percent. The filter range for the low pressure circuit is completed by suitable tank two-way ventilation air cleaners. The target here is to minimize the ingress of dirt in the fuel circuit caused by the exchange of air to reduce the level of contamination in the fuel tank and consequently to further improve the purity level of the fuel.

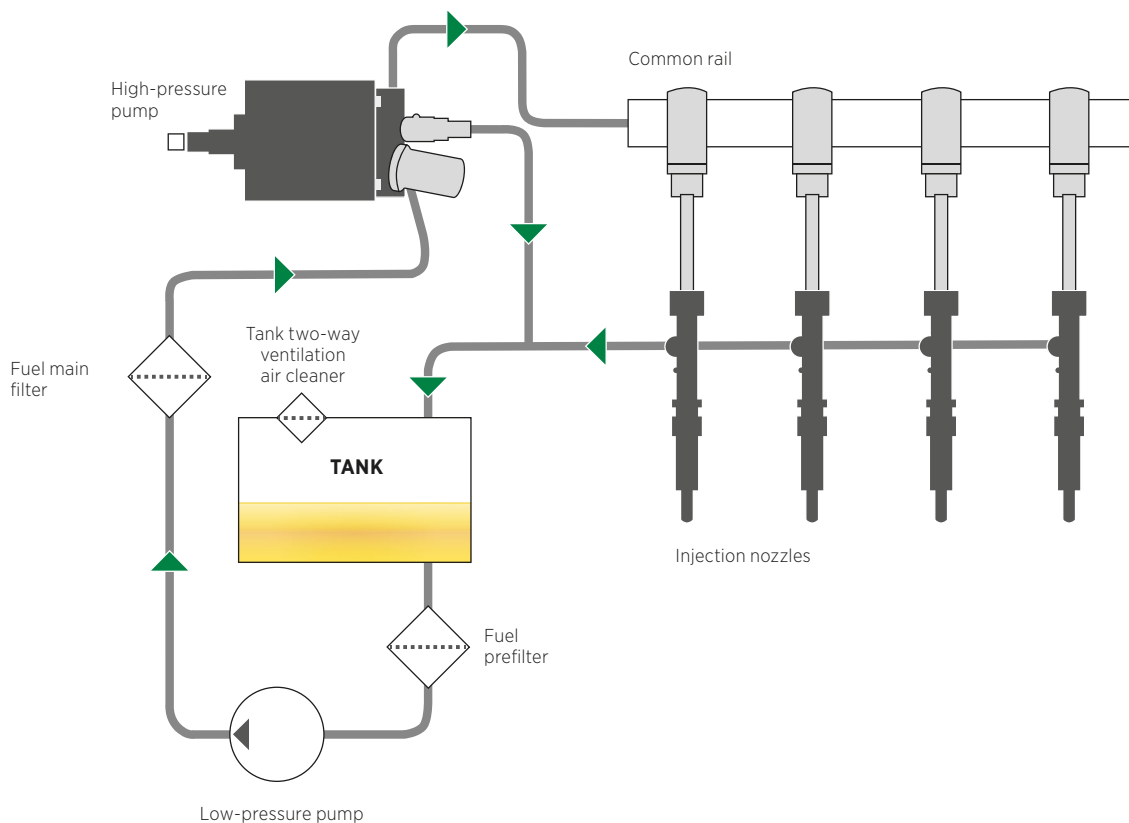

Media technology

Multigrade F

Modern diesel injection systems require the best fuel quality and therefore place the highest demands on fuel filtration. The MANN+HUMMEL Multigrade media were specially developed for diesel engines and meet the high requirements of well-known injection system manufacturers. The multi-layer structure of the Multigrade media enables the highest dirt holding capacities and finest particle separation.

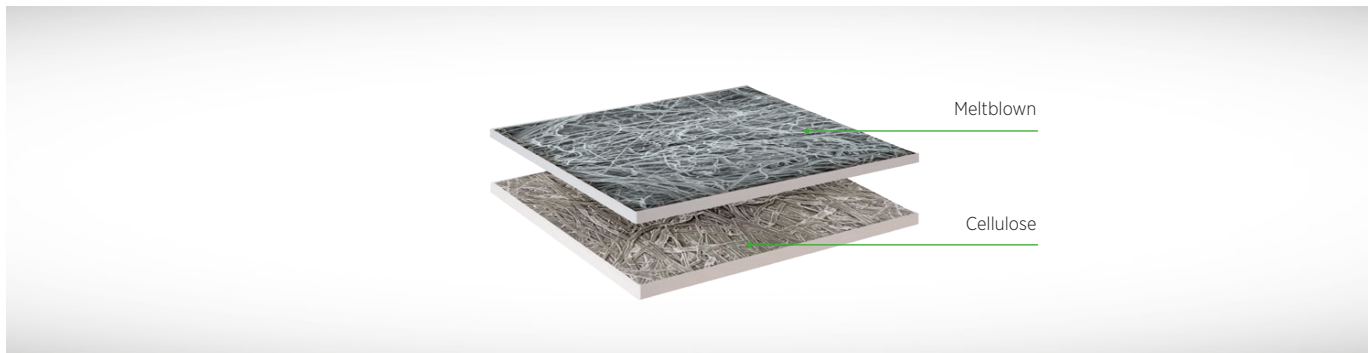

MULTIGRADE F-PF AND PFO

- Initial separation efficiency for $4\ \mu\text{m}$ > 10% to 30%
- Water separation > 93%

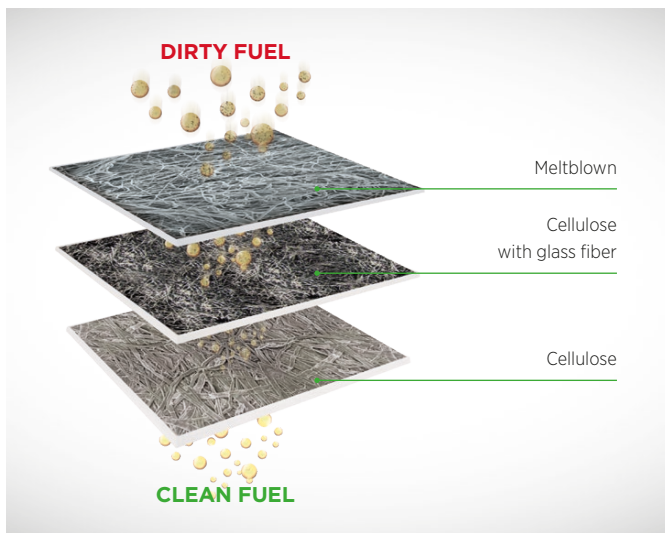

MULTIGRADE F-MB 333.1

- Initial separation efficiency according to ISO 19 438:2003 for $4\ \mu\text{m}$ > 99.7% ($\beta_4=20$ to $\beta_4=333$)
- Dirt holding capacity up to $110\ \text{g/m}^2$ according to ISO 4020 - 6.4
- Cellulose layer on the downstream side

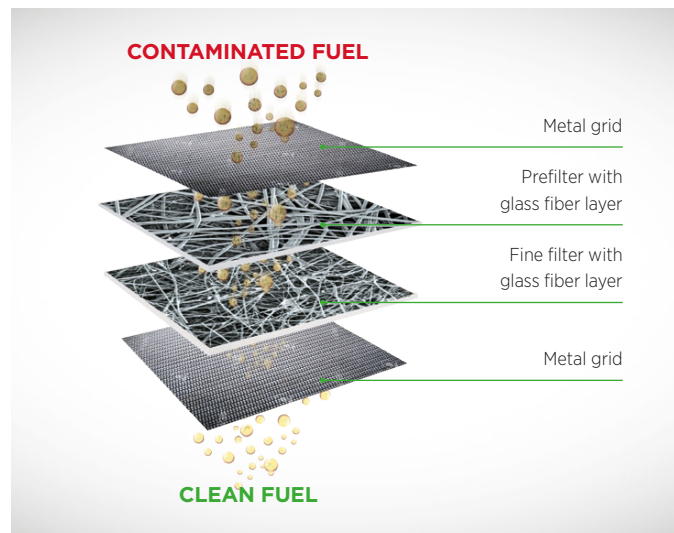

MULTIGRADE F-G 5000.1

- Initial separation efficiency according to ISO 19 438:2003 for $4\ \mu\text{m}$ > 99.98% ($\beta_4=20$ to $\beta_4=333$)
- Dirt holding capacity up to $190\ \text{g/m}^2$ according to ISO 4020 - 6.4
- Spunbond layer on the downstream side

Media technology

Water separation

Not only dirt particles, but also water droplets have a direct effect on the components of the injection system. This applies in particular to modern common rail systems which place high requirements on the purity of the fuel. For this reason, in addition to particle filters, water separators are also needed to reliably remove the water droplets from the fuel.

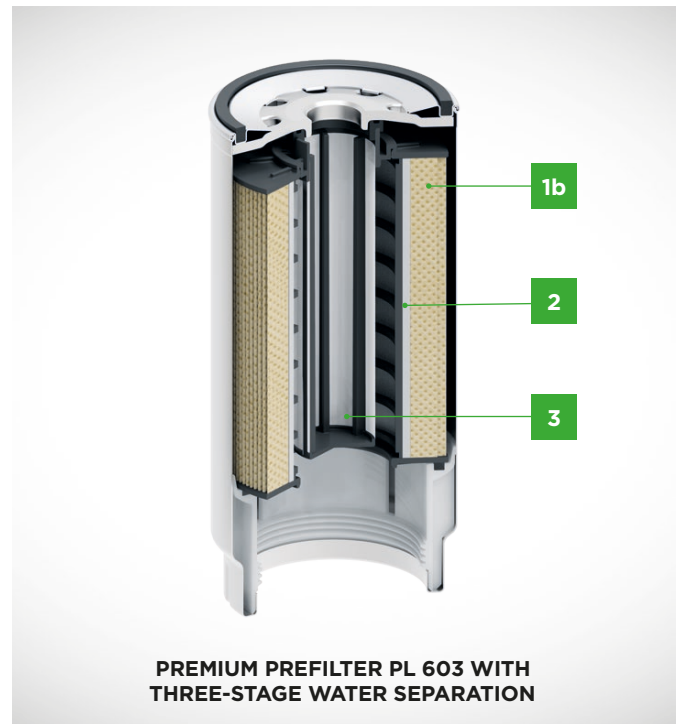

FUNCTION

MANN+HUMMEL has developed an innovative three-stage filter concept to ensure reliable water separation for the complete service life of the filter element. While with conventional filter systems the water on the dirty side is separated using a hydrophobic filter medium (1a), in the first stage of the premium prefilter solid particles are separated (1b). A coalescer downstream then combines small water droplets (2). These are then retained by a hydrophobic fabric in the center of the filter system and separated downwards by means of gravity (3).

ADVANTAGES AT A GLANCE

- The new PL 603 is compatible to the existing PreLine modular series
- Up to 60 percent higher volume flow rates possible with the same installation space
- Constant water separation under real operating conditions for the complete service life of the filter
- Up to 20 percent more dirt holding capacity
- Highly efficient protection of the injection system against water and particles

Note: On request available as PL 603 and PL 1003.



Fuel filters

PreLine prefilters

The MANN+HUMMEL PreLine prefilter series reduces the contamination level of fuel already upstream of the pre-feed pump in the low pressure circuit. In addition, the Multigrade F filter media separate more than 93 percent of any water in the fuel and therefore meet the requirements of leading manufacturers of injection systems. The perfect interaction between the PreLine prefilter and the MANN+HUMMEL main filter offers maximum protection for the sensitive injection system and contributes to the economic running of your engine.

VOLUME FLOW RANGE WITH SINGLE FILTER HEAD

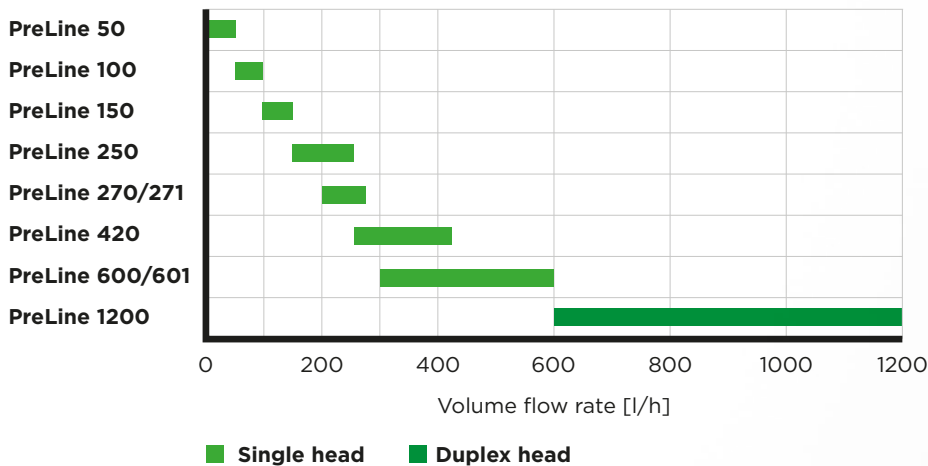

Note:

- Several PreLine filters of the same design and size can be fitted in parallel in order to correspondingly increase the volume flow rate by the same factor.
- Preline filters are not designed for use in series and/or different sizes.

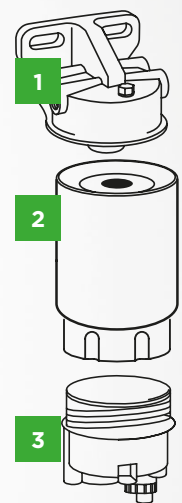

1 FILTER HEADS

More information on filter heads is available from page 18.

2 SPIN-ON FILTERS

Available for nominal flow rates from 50 l/h to 600 l/h. More information on the combination possibilities of the filter heads and spin-on filters is available from page 19.

3 ACCESSORIES

More information on suitable accessories is available from page 36.

Filter systems

PreLine 50



MAIN FEATURES AND ADVANTAGES

- For use with diesel fuel DIN ISO 590 (5% FAME), DIN 51 628 (7% FAME), kerosene JET-A1
- For volume flow rates up to 50 l/h
- Use of 'multigrade high performance' media
- 93% water separation
- Modular system for excellent flexibility
- Easy handling during servicing
- Integrated and effective hand pump with 45° position to drain off water and for priming during service
- Integrated water collector
- Parallel operation possible with a number of systems
- PreLine 50/2 can be used as combined prefilter and main filter for applications where installation space is critical

Specifications	Initial separation efficiency according to ISO 19 438:2003				PreLine 50	PreLine 50/1	PreLine 50/2
	Classes	4 µm (c)	10 µm (c)	30 µm (c)			
Filter medium	Multigrade F_PFO	≥ 10%	≥ 80%	≥ 99%	x	-	-
	Multigrade F_PF	≥ 40%	≥ 99%	≥ 99%	-	x	-
	Multigrade F_HE	≥ 95%	≥ 99%	≥ 99%	-	-	x
Nominal volume flow	[l/h]				50		
Application	Prefilter function with water separation				x		
Water separation	according to ISO/TR 16 332 [%]				> 93		
Operating pressure	Filter system [bar]				4		
Filter head	Connections	Inlet dirty side		Respectively right and left 2 x M16x1.5 Permanently installed hand pump Mounting for diesel heater either on left or right			
		Outlet clean side					
Dimensions	Height x width x depth [mm]				98 x 102 x 197		

Type	Medium	Order no. filter systems	MANN-FILTER spin-on filter	Water level sensor	Hand pump	Water collector	Diesel heater with bi-metal control	
							12 volt	24 volt
PreLine 50	PFO	66 401 62 140 66 401 62 144	PL 50	yes no				
PreLine 50/1	PF	66 401 62 150 66 401 62 154	PL 50/1	yes no	yes	integrated in spin-on filter	DH 12 (optional)	DH 24 (optional)
PreLine 50/2	HE	66 401 62 180 66 401 62 184	PL 50/2	yes no				

Filter systems

PreLine 100 and 150



MAIN FEATURES AND ADVANTAGES

- For use with diesel fuel DIN ISO 590 (5% FAME) DIN 51 628 (7% FAME) kerosene JET-A1
- For volume flow rates respectively up to 100 or 150 l/h
- Use of 'multigrade high performance' media
- 93% water separation
- Modular system for excellent flexibility
- Easy handling during servicing
- Integrated and effective hand pump with 45° position to drain off water and for priming during service
- Integrated water collector
- Parallel operation possible with a number of systems
- PreLine 100/2 can be used as combined prefilter and main filter for applications where installation space is critical

Specifications	Initial separation efficiency according to ISO 19 438:2003				PreLine 100/2	PreLine 150	PreLine 150/1
	Classes	4 µm (c)	10 µm (c)	30 µm (c)			
Filter medium	Multigrade F_PFO	≥ 10%	≥ 80%	≥ 99%	-	x	-
	Multigrade F_PF	≥ 40%	≥ 99%	≥ 99%	-	-	x
	Multigrade F_HE	≥ 95%	≥ 99%	≥ 99%	x	-	-
Nominal volume flow	[l/h]				100	150	150
Application	Prefilter function with water separation				x	x	x
	Additional main filter function				x	no	no
Water separation	according to ISO/TR 16 332 [%]				> 93		
Operating pressure	Filter system [bar]				4		
Filter head	Connections	Inlet dirty side		Respectively right and left 2 x M16x1.5			
		Outlet clean side		Permanently installed hand pump			
				Mounting for diesel heater either on left or right			
Dimensions	Height x width x depth [mm]				98 x 102 x 247		

Type	Medium	Order no. filter systems	MANN-FILTER spin-on filter	Water level sensor	Hand pump	Water collector	Diesel heater with bi-metal control	
							12 volt	24 volt
PreLine 100/2	HE	66 402 62 180 66 402 62 184	PL 100/2	yes no				
PreLine 150	PFO	66 402 62 140 66 402 62 144	PL 150	yes no	yes	integrated in spin-on filter	DH 12 (optional)	DH 24 (optional)
PreLine 150/1	PF	66 402 62 150 66 402 62 154	PL 150/1	yes no				

Filter systems

PreLine 150



MAIN FEATURES AND ADVANTAGES

- For volume flow rates up to 150 l/h
- Use of 'multigrade high performance' media
- 93% water separation
- Modular system for excellent flexibility
- Easy handling during servicing
- Priming during service
- Transparent bowl with extra-large water collector
- Parallel operation possible with a number of systems
- Excellent protection of the low pressure pump against wear from particles

Specifications	Initial separation efficiency according to ISO 19 438:2003				PreLine 150/30	PreLine 150/31	PreLine 150/32
	Classes	4 µm (c)	10 µm (c)	30 µm (c)			
Filter medium	Multigrade F_PFO	≥ 10%	≥ 80%	≥ 99%	x	-	-
	Multigrade F_PF	≥ 40%	≥ 99%	≥ 99%	-	x	-
	Multigrade F_HE	≥ 95%	≥ 99%	≥ 99%	-	-	x
Nominal volume flow	[l/h]				150	150	150
Application	Particle pre-filtration and water separation				x	x	x
Water separation	At 150 l/h volume flow rate, according to ISO/TR 16 332 [%]				> 93		
Operating pressure	Filter system [bar]				0,5		
Filter head	Connections				2 x dirty and clean side with M16x1,5		
Dimensions	Height x width x depth [mm]				272 x 97 x 105		

Type	Medium	Order no. filter systems	MANN-FILTER spin-on filter	Water level sensor	Hand pump	Water collector	Diesel heater with bi-metal control	
							12 volt	24 volt
PreLine 150/30	PFO	66 503 62 142	PL 150/30 X					
PreLine 150/31	PF	66 503 62 152	PL 150/31 X	no	no	yes	DH 12 (optional)	DH 24 (optional)
PreLine 150/32	HE	66 503 62 162	PL 150/32 X					

Filter systems

PreLine 250



MAIN FEATURES AND ADVANTAGES

- For use with diesel fuel DIN ISO 590 (5% FAME) DIN 51 628 (7% FAME) kerosene JET-A1
- For volume flow rates up to 250 l/h
- Use of 'multigrade high performance' media
- 93% water separation
- Modular system for excellent flexibility
- Easy handling during servicing
- Integrated and effective hand pump with 45° position to drain off water and for priming during service
- Integrated water collector
- Parallel operation possible with a number of systems

Specifications	Initial separation efficiency according to ISO 19 438:2003				PreLine 250	PreLine 250/1
	Classes	4 µm (c)	10 µm (c)	30 µm (c)		
Filter medium	Multigrade F_PFO	≥ 10%	≥ 80%	≥ 99%	x	-
	Multigrade F_PF	≥ 40%	≥ 99%	≥ 99%	-	x
Nominal volume flow	[l/h]				250	250
Application	Prefilter function with water separation				x	x
	Additional main filter function				no	no
Water separation	according to ISO/TR 16 332 [%]				> 93	
Operating pressure	Filter system [bar]				4	
Filter head	Connections	Inlet dirty side		Respectively right and left 2 x M16x1.5 Permanently installed hand pump Mounting for diesel heater either on left or right		
		Outlet clean side				
Dimensions	Height x width x depth [mm]				98 x 102 x 275	

Type	Medium	Order no. filter systems	MANN-FILTER spin-on filter	Water level sensor	Hand pump	Water collector	Diesel heater with bi-metal control	
							12 volt	24 volt
PreLine 250	PFO	66 504 62 140 66 504 62 144	PL 250	yes no	yes	integrated in spin-on filter	DH 12 (optional)	DH 24 (optional)
PreLine 250/1	PF	66 504 62 150 66 504 62 154	PL 250/1	yes no				

Filter systems

PreLine 270



MAIN FEATURES AND ADVANTAGES

- For use with diesel fuel DIN ISO 590 (5% FAME) DIN 51 628 (7% FAME)
- For volume flow rates up to 270 l/h
- Use of 'multigrade high performance' media
- 93% water separation
- Modular system for excellent flexibility
- Easy handling during servicing
- Integrated and effective hand pump with 45° position to drain off water and for priming during service
- Large external water collector
- Parallel operation possible with a number of systems

Specifications	Initial separation efficiency according to ISO 19 438:2003				PreLine 270	PreLine 270/1
	Classes	4 µm (c)	10 µm (c)	30 µm (c)		
Filter medium	Multigrade F_PFO	≥ 10%	≥ 80%	≥ 99%	x	-
	Multigrade F_PF	≥ 40%	≥ 99%	≥ 99%	-	x
Nominal volume flow	[l/h]				270	270
Application	Particle pre-filtration and water separation				x	x
	Additional main filter function				no	no
Water separation	according to ISO/TR 16 332 [%]				> 93	
Operating pressure	Filter system [bar]				4	
Filter head	Connections	Inlet dirty side		Only left 1 x M18x1.5 With or without hand pump Mounting for diesel heater on right		
		Outlet clean side				
Dimensions	Height x width x depth [mm]				120 x 125 x 326	

Type	Medium	Order no. filter systems	MANN-FILTER spin-on filter	Water level sensor	Hand pump	Water collector	Diesel heater with bi-metal control	
							12 volt	24 volt
PreLine 270	PFO	66 604 62 261	PL 270 X	yes	yes	yes	DH 12 (optional)	DH 24 (optional)
		66 604 62 263		no	no			
		66 604 62 265		yes	yes			
		66 604 62 267		yes	no			
PreLine 270/1	PF	66 604 62 251	PL 270/1 X	yes	yes	yes	DH 12 (optional)	DH 24 (optional)
		66 604 62 253		no	no			
		66 604 62 255		no	yes			
		66 604 62 257		yes	no			

Filter systems

PreLine 420



MAIN FEATURES AND ADVANTAGES

- For use with diesel fuel DIN ISO 590 (5% FAME) DIN 51 628 (7% FAME)
- For volume flow rates up to 420 l/h
- Use of 'multigrade high performance' media
- 93% water separation
- Modular system for excellent flexibility
- Easy handling during servicing
- Integrated and effective hand pump with 45° position to drain off water and for priming during service
- Large external water collector
- Parallel operation possible with a number of systems

Specifications	Initial separation efficiency according to ISO 19 438:2003				PreLine 420	PreLine 420/1
	Classes	4 µm (c)	10 µm (c)	30 µm (c)		
Filter medium	Multigrade F_PFO	≥ 10%	≥ 80%	≥ 99%	x	-
	Multigrade F_PF	≥ 40%	≥ 99%	≥ 99%	-	x
Nominal volume flow	[l/h]				420	420
Application	Particle pre-filtration and water separation				x	x
	Additional main filter function				no	no
Water separation	according to ISO/TR 16 332 [%]				> 93	
Operating pressure	Filter system [bar]				4	
Filter head	Connections	Inlet dirty side		Only left 1 x M18x1.5 With or without hand pump Mounting for diesel heater on right		
		Outlet clean side				
Dimensions	Height x width x depth [mm]				120 x 130 x 406	

Type	Medium	Order no. filter systems	MANN-FILTER spin-on filter	Water level sensor	Hand pump	Water collector	Diesel heater with bi-metal control	
							12 volt	24 volt
PreLine 420	PFO	66 606 62 261	PL 420 X	yes	yes	yes	DH 12 (optional)	DH 24 (optional)
		66 606 62 263		no	no			
		66 606 62 265		no	yes			
		66 606 62 267		yes	no			
PreLine 420/1	PF	66 606 62 251	PL 420/1 X	yes	yes	yes	DH 12 (optional)	DH 24 (optional)
		66 606 62 253		no	no			
		66 606 62 255		no	yes			
		66 606 62 257		yes	no			

Filter systems

PreLine 601



MAIN FEATURES AND ADVANTAGES

- For use with diesel fuel DIN ISO 590 (5% FAME) DIN 51 628 (7% FAME)
- For volume flow rates up to 600 l/h
- Use of 'multigrade high performance' media
- 93% water separation
- Modular system for excellent flexibility
- Easy handling during servicing
- Integrated and effective hand pump with 45° position to drain off water and for priming during service
- Integrated water collector
- Parallel operation possible with a number of systems

Specifications	Initial separation efficiency according to ISO 19 438:2003				PreLine 601	PreLine 601/1
	Classes	4 µm (c)	10 µm (c)	30 µm (c)		
Filter medium	Multigrade F_PFO	≥ 10%	≥ 80%	≥ 99%	x	-
	Multigrade F_PF	≥ 40%	≥ 99%	≥ 99%	-	x
Nominal volume flow	[l/h]				600	600
Application	Particle pre-filtration and water separation				x	x
	Additional main filter function				no	no
Water separation	according to ISO/TR 16 332 [%]				> 93	
Operating pressure	Filter system [bar]				4	
Filter head	Connections	Inlet dirty side		Only left 1 x M18x1.5 With or without hand pump Mounting for diesel heater on right		
		Outlet clean side				
Dimensions	Height x width x depth [mm]				120 x 125 x 371	

Type	Medium	Order no. filter systems	MANN-FILTER spin-on filter	Water level sensor	Hand pump	Water collector	Diesel heater with bi-metal control	
							12 volt	24 volt
PreLine 601	PFO	66 607 62 160 66 607 62 164	PL 601	yes no	yes yes	integrated in spin-on filter	DH 12 (optional)	DH 24 (optional)
PreLine 601/1	PF	66 607 62 150 66 607 62 154	PL 601/1	yes no	yes yes			

Filter head

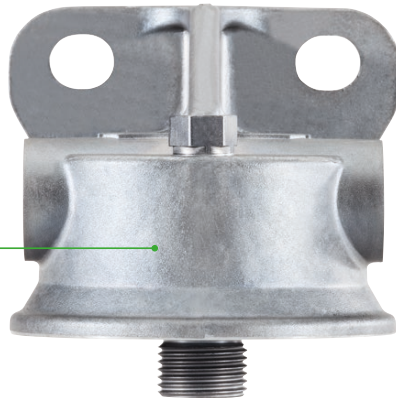

Spin-on filter



Bowl



Drain plug



Water sensor



Filter heads

Selection



SINGLE HEAD

- Variable connection possibilities
- Robust design in different sizes
- Designed for easy servicing



SINGLE HEAD WITH ADDITIONAL FUNCTIONS

- Simplified system venting through integrated hand pump
- Resistance heater available as option
- Integrated electric fuel pump available as option



DUPLEX HEAD

- Variable connection possibilities
- For the highest requirements regarding resistance to vibration and fatigue strength
- Integrated Δp sensor available as option

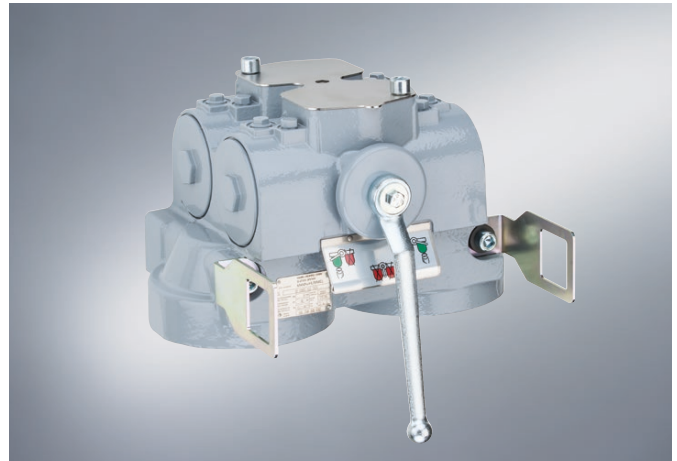

DUPLEX SWITCHABLE HEAD

- Precision switching for perfect filter change during operation
- Developed for marine, railway and genset applications
- SOLAS (Safety of life at sea) certification as option

Filter heads and prefilters up to 150 l/h

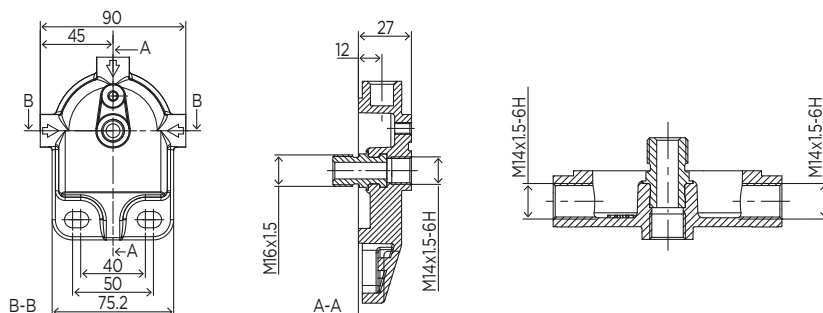

FILTER HEADS

Order no.	Picture	Material	Filter head	Spin-on filter connection	Nominal flow rate [l/h]	Application
66 404 31 981	1	Aluminium	Compact flat filter head ideal for very compact installation space	M16x1.5	150	Standard requirements for compact installation space

SUITABLE PREFILTERS for filter head 66 404 31 981

Type	Diameter [mm]	Length [mm]	Separation efficiency [%] ISO 19438 Particle size: 4 µm	Permissible operating pressure [bar]	Volume flow [l/h]
WK 713	76	133	80	6	100
WDK 725	76	153	58	6	130
WK 821	81	106	25	6	150
WDK 724/1	76	153	80	7	150
WK 724/3	76	146	80	6	150
WK 842	81	133	25	8	150
WK 842/2	81	133	35	6	150
PL 50	76	89	10	4	50
PL 50/1	76	89	40	4	50
PL 50/2	76	89	94	4	50
PL 100/2	76	163	94	4	100
PL 150	76	146	10	4	150
PL 150/1	76	163	40	4	150



ACCESSORIES

Suitable accessories are available from page 36.

Filter heads and prefilters up to 250 l/h

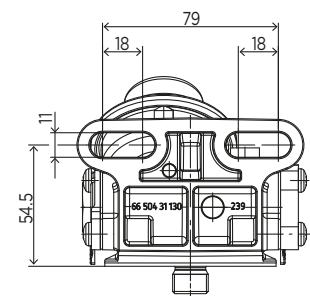
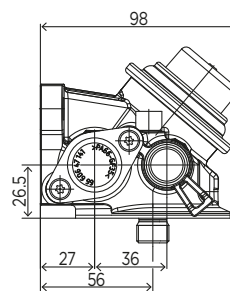
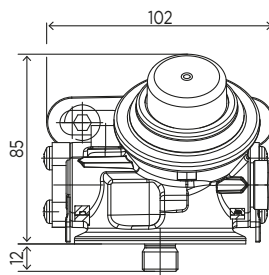
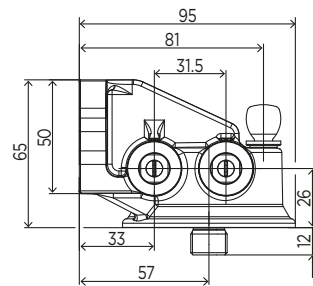
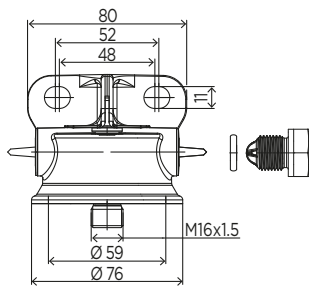

FILTER HEADS

Order no.	Picture	Material	Filter head	Spin-on filter connection	Nominal flow rate [l/h]	Application
66 508 31 994	1	Aluminium	Standard filter head with vent hole and several connection possibilities	M16x1.5	250	Standard requirements
66 504 31 991	2	Aluminium	Standard filter head with vent hole including hand pump and connection possibilities for electric resistance heater	M16x1.5	250	Additional requirements, e.g. hand pump and/or electric resistance heater (optional)

Filter heads and prefilters up to 250 l/h

SUITABLE PREFILTERS for all filter heads are available on page 20

Type	Diameter [mm]	Length [mm]	Separation efficiency [%] ISO 19438 Particle size: 4 µm	Permissible operating pressure [bar]	Volume flow [l/h]
WK 713	76	133	80	6	100
WDK 725	76	153	58	6	130
WK 821	81	106	25	6	150
WDK 724/1	76	153	80	7	150
WK 724/3	76	146	80	6	150
WK 842	81	133	25	8	150
WK 842/2	81	133	35	6	150
PL 50	76	89	10	4	50
PL 50/1	76	89	40	4	50
PL 50/2	76	89	94	4	50
PL 100/2	76	163	94	4	100
PL 150	76	146	10	4	150
PL 150/1	76	163	40	4	150
PL 150/30*	96	140	10	0.5	150
PL 150/31*	96	140	40	0.5	150
PL 150/32*	96	140	94	0.5	150
PL 250/1	93	192	40	4	250
PL 250	93	192	10	4	250

* with transparent bowl



ACCESSORIES
Suitable accessories are available from page 36.

Filter heads and prefilters up to 1,200 l/h



1

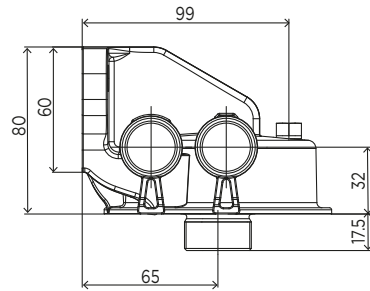
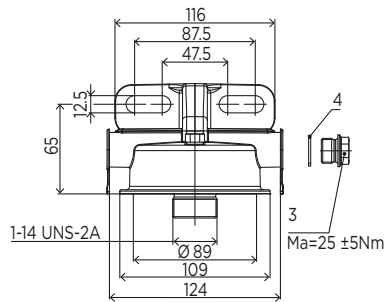

2

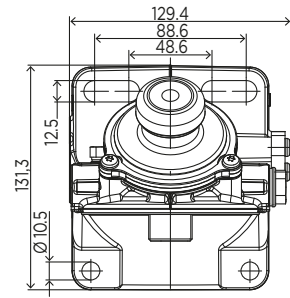
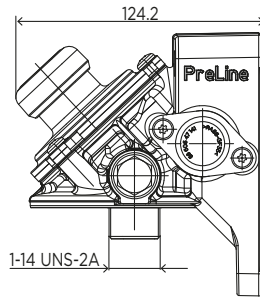

3

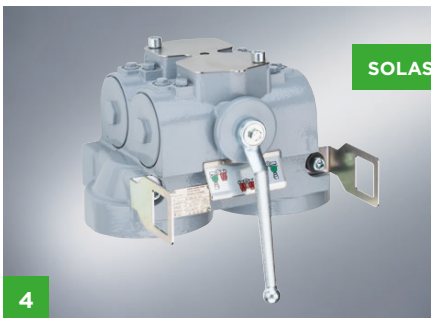
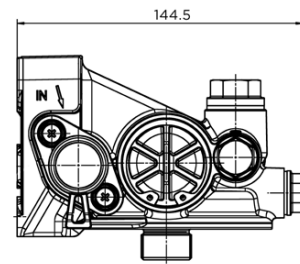
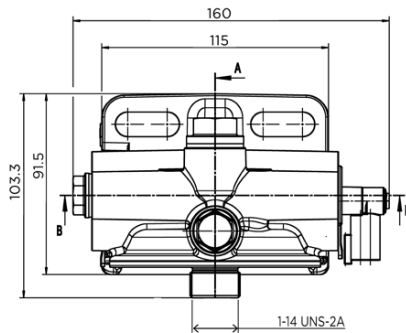

4

SOLAS

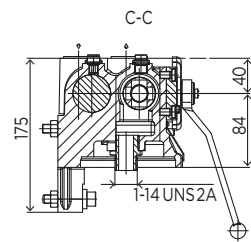
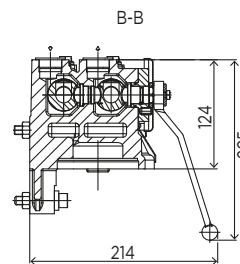
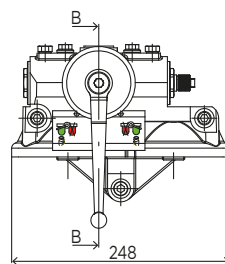

Filter heads and prefilters up to 1,200 l/h

FILTER HEADS

Order no.	Picture	Material	Filter head	Spin-on filter connection	Nominal flow rate [l/h]	Application
12 591 54 S01	1	Aluminium	Standard filter head with vent hole and several connection possibilities	1-14 UNS	600	High requirements regarding resistance to vibrations and fatigue strength
66 606 31 951	2	Aluminium	Standard filter head with vent hole including hand pump and connection possibilities for electric resistance heater	1-14 UNS	600	Additional requirements, e.g. hand pump and/ or electric resistance heater (optional)
On request	3	Aluminium	Filter head with integrated electric fuel pump and connection possibilities for electric resistance heating	1-14 UNS	600	Particularly for applications with difficult starting conditions, difficult access for servicing and low pressure drop requirements
66 612 31 974	4	Steel	Duplex filter head with precision switching for perfect filter change	1-14 UNS	1,200	SOLAS certified filter head, particularly suitable for marine or genset applications

SUITABLE PREFILTERS for all filter heads are available on page 22

Type	Diameter [mm]	Length [mm]	Separation efficiency [%] ISO 19438 Particle size: 4 µm	Permissible operating pressure [bar]	Volume flow [l/h]
PL 270	108.0	150.0	10	4	270
PL 270/1	108.0	150.0	40	4	270
PL 271/1*	108.0	185.0	40	4	270
PL 420	108.0	231.4	10	4	420
PL 420/1	108.0	230.0	40	4	420
PL 420/2	108.0	231.0	58	4	420
PL 600	108.0	230.0	10	4	600
PL 600/1	108.0	231.4	40	4	600
PL 601*	108.0	268.0	10	4	600
PL 601/1*	108.0	268.0	40	4	600

*with integrated water collector



ACCESSORIES

Suitable accessories are available from page 36.



Fuel filters

Main filters

MANN+HUMMEL main filters for diesel fuel offer ideal protection for your injection system. Depending on the requirements, our range of media offers various levels of filter fineness, in different sizes and with different lengths of service life. Choose exactly the combination of filter head and spin-on filter for your application from a wide range.

VOLUME FLOW RANGE WITH MAIN FILTERS

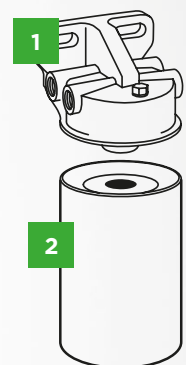
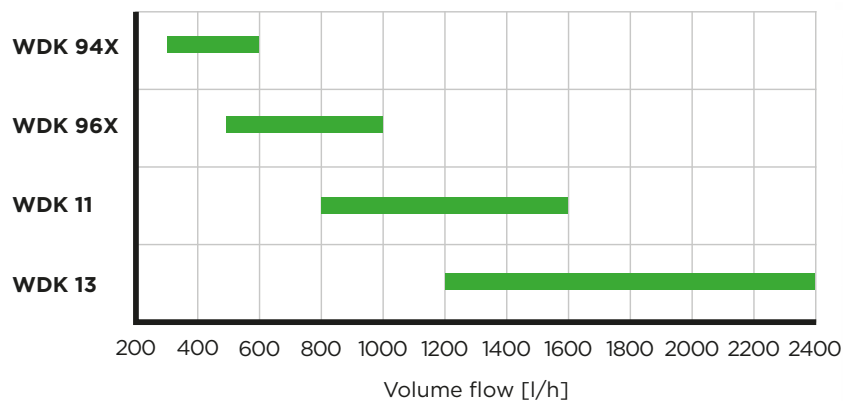

1 FILTER HEADS

Available for volume flow rates from 50 l/h to approximately 1,400 l/h for single heads. With the enhanced duplex head versions, volume flow rates up to 2,800 l/h are possible. More information on filter heads is available from page 18.

2 SPIN-ON FILTERS

Available up to approximately 1,100 l/h for different filter fineness levels up to Beta = 10,000. More information on combination possibilities for filter heads and spin-on filters is available from page 27.

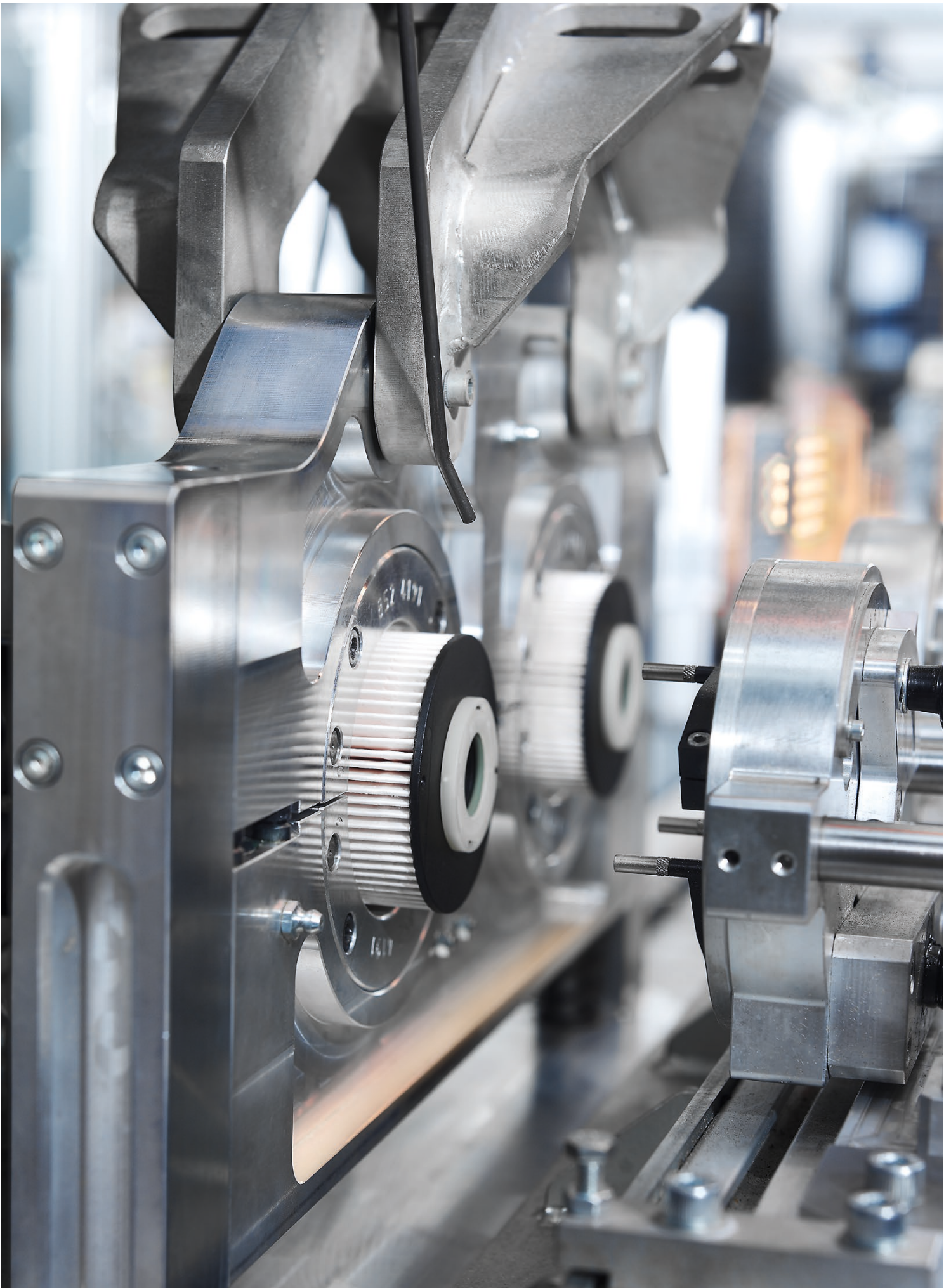

Filter heads and spin-on filters up to 600 l/h

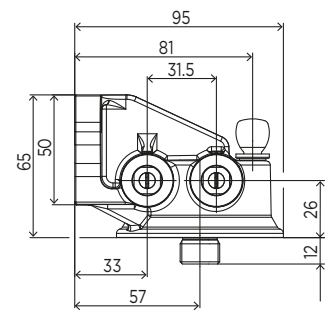
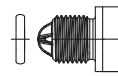
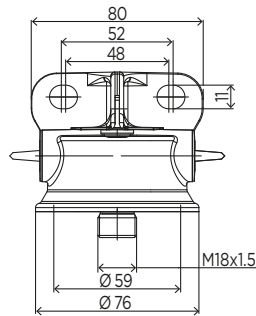

FILTER HEAD

Order no.	Picture	Material	Filter head	Spin-on filter connection	Nominal flow rate [l/h]	Application
66 508 31 995	1	Aluminium	Standard filter head with vent hole and several connection possibilities	M18x1.5	600	High requirements regarding resistance to vibrations and fatigue strength

SUITABLE SPIN-ON FILTERS

Type	Diameter [mm]	Length [mm]	Separation efficiency [%] ISO 19438 Particle size: 4 µm	Permissible operating pressure [bar]	Volume flow [l/h]
WK 940/20	93.3	150.0	80.0	10	300
WDK 940/1	93.0	150.0	98.0	10	300
WDK 940/20	93.3	150.0	99.8	10	230
WK 962/7	93.0	210.0	80.0	7	600
WDK 962/1	93.3	214.5	98.0	10	500
WDK 962/20	93.3	214.5	99.8	10	330



ACCESSORIES
Suitable accessories are available from page 36.

Filter heads and spin-on filters up to 1,600 l/h



1

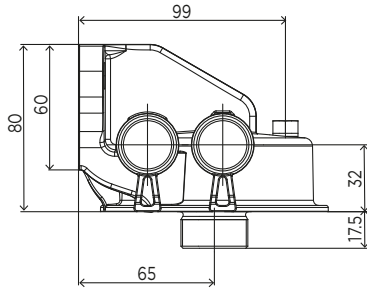
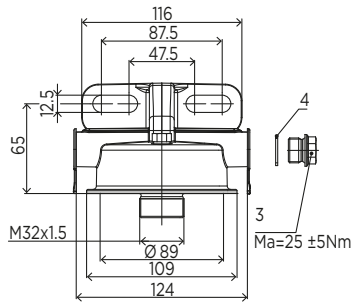

2

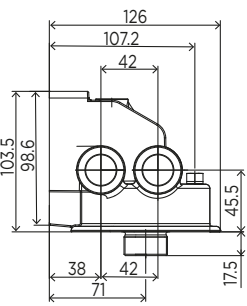
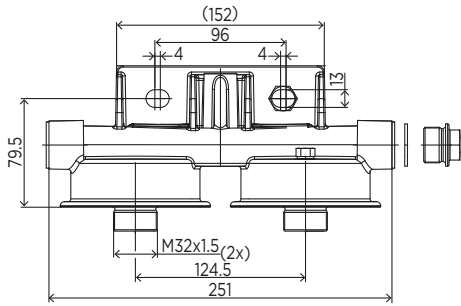

3

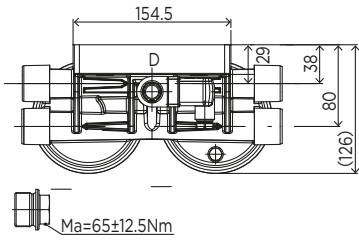
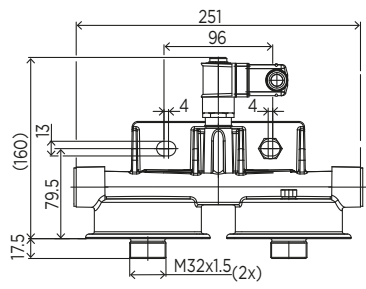

4

SOLAS

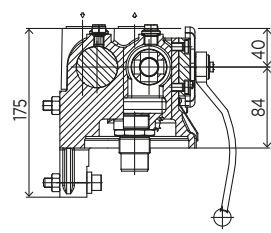
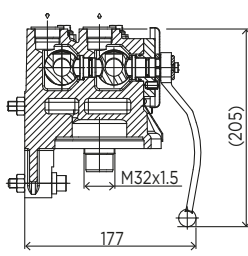
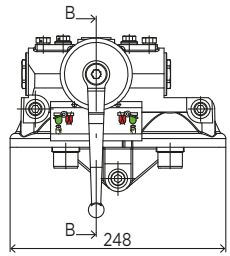

Filter heads and spin-on filters up to 1,600 l/h

FILTER HEAD

Order no.	Picture	Material	Filter head	Spin-on filter connection	Nominal flow rate [l/h]	Application
66 610 31 140	1	Aluminium	Standard filter head with vent hole and several connection possibilities	M32x1.5	800	Highest requirements regarding resistance to vibrations and fatigue strength
12 514 64 S01	2	Aluminium	Standard duplex filter head with vent hole and several connection possibilities as well as integrated Δp sensor	M32x1.5	1,600	Highest requirements regarding resistance to vibrations and fatigue strength
12 514 65 S01	3	Aluminium	Standard duplex filter head with vent hole and several connection possibilities as well as integrated Δp sensor	M32x1.5	1,600	Highest requirements regarding resistance to vibrations and fatigue strength
66 612 31 972	4	Steel	Duplex filter head with precision switching for perfect filter change	M32x1.5	1,600	SOLAS certified filter head, particularly suitable for marine or genset applications

SUITABLE SPIN-ON FILTERS

Type	Diameter [mm]	Length [mm]	Separation efficiency [%] ISO 19438 Particle size: 4 μm	Permissible operating pressure [bar]	Volume flow [l/h]
WDK 11 102/2	108.0	263.0	80.0	10	800
WDK 11 102/23	108.0	263.0	85.0	7	600
WDK 11 102/24	108.0	263.0	85.0	7	600
WDK 11 102/10	108.0	263.0	94.0	10	800
WDK 11 102/17	108.0	263.0	94.0	7	800
WDK 11 102/8	108.0	263.0	94.0	12	700
WDK 11 102/3	108.0	263.0	98.0	7	800
WDK 11 102/4	108.0	263.0	98.0	7	600
WDK 11 102/5	108.0	263.0	98.0	10	800
WDK 11 102/21	108.0	263.0	99.8	10	800



ACCESSORIES
Suitable accessories are available from page 36.

Filter heads and spin-on filters up to 2,800 l/h



1

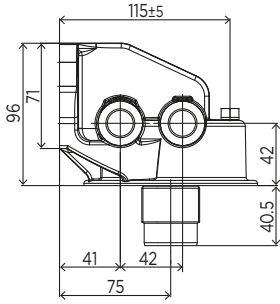
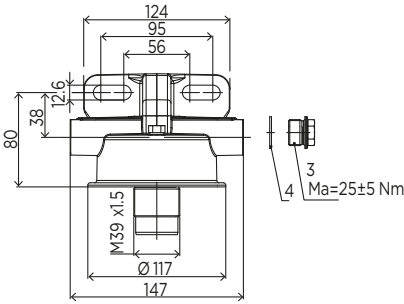

2

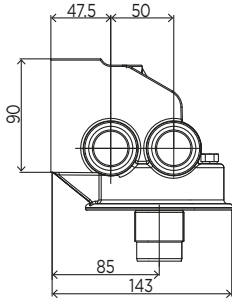
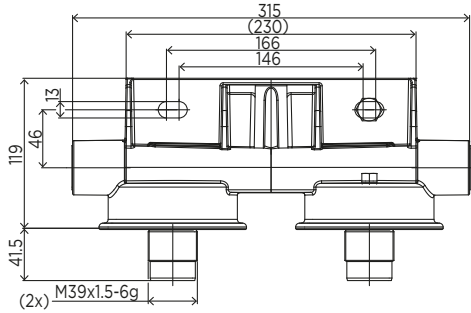

3

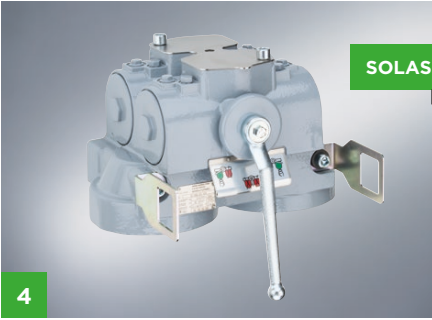
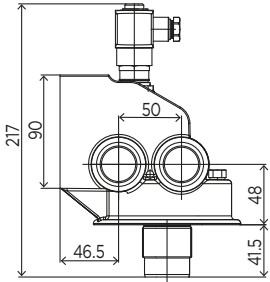
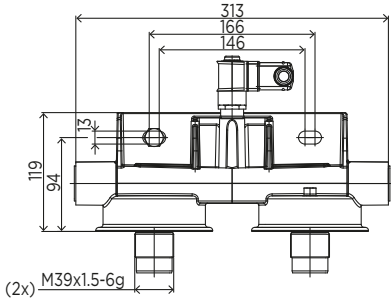

4

SOLAS

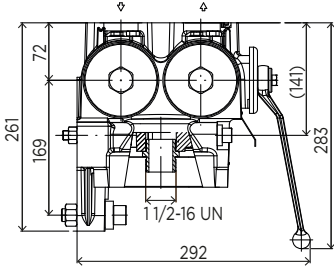
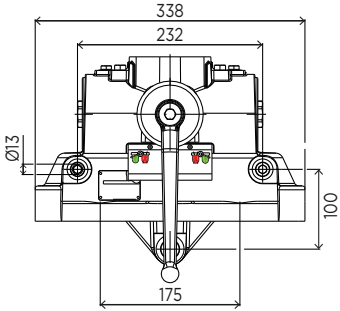

Filter heads and spin-on filters up to 2,800 l/h

FILTER HEAD

Order no.	Picture	Material	Filter head	Spin-on filter connection	Nominal flow rate [l/h]	Application
12 610 73 S01	1	Aluminium	Standard filter head with vent hole and several connection possibilities	M39x1.5	1,400	Highest requirements regarding resistance to vibrations and fatigue strength
12 514 66 S01	2	Aluminium	Standard duplex filter head with vent hole and several connection possibilities as well as integrated Δp sensor	M39x1.5	2,800	Highest requirements regarding resistance to vibrations and fatigue strength
12 514 67 S01	3	Aluminium	Standard duplex filter head with vent hole and several connection possibilities as well as integrated Δp sensor	M39x1.5	2,800	Highest requirements regarding resistance to vibrations and fatigue strength
12 024 41 S01	4	Steel	Duplex filter head with precision switching for perfect filter change	M39x1.5	2,800	SOLAS certified filter head, particularly suitable for marine or genset applications

SUITABLE SPIN-ON FILTERS

Type	Diameter [mm]	Length [mm]	Separation efficiency [%] ISO 19438 Particle size: 4 μm	Permissible operating pressure [bar]	Volume flow [l/h]
WDK 13 145	136	302	80.0	11	1,100
WDK 13 145/1	136	302	94.0	14	1,100
WDK 13 145/2	136	302	99.8	10	1,100



ACCESSORIES
Suitable accessories are available from page 36.

Fuel filters Tank two-way ventilation air cleaners

Two-way ventilation air cleaners from MANN+HUMMEL ensure that during the pressure compensation of liquid and transmission tanks no contamination occurs through the ingress of particles. This reliably maintains the purity class of the fuel.



Fuel filters

Tank two-way ventilation air cleaners

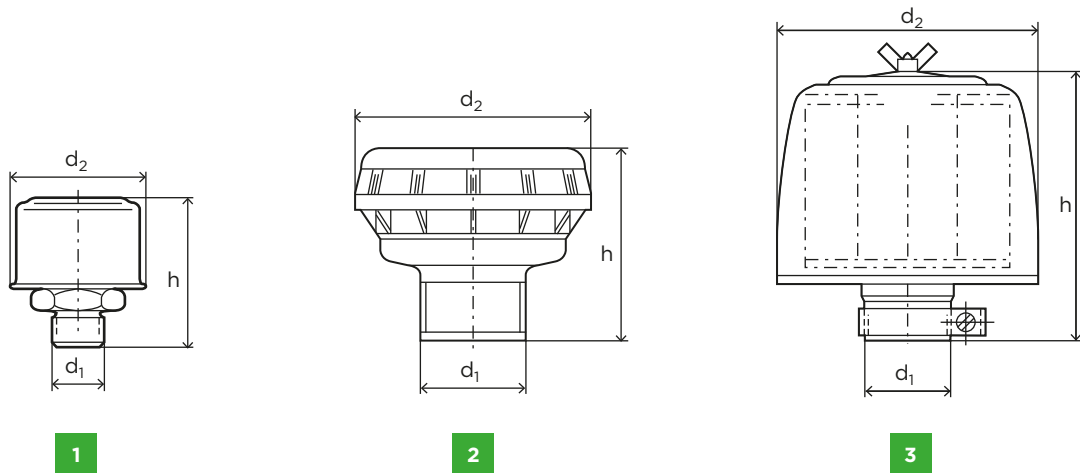

Order no.	Picture	Volume flow [m ³ /min]	Opening pressure		Dimensions [mm]			MANN-FILTER main element	Weight [kg]
			[bar]	[kPa]	d ₁	d ₂	h		
45 001 62 185	1	-	-	-	M18x1.5	45	47	- ¹⁾	0.08
45 003 65 900	2	-	-	-	35	80	65	- ¹⁾	0.06
45 003 62 902	2	-	-	-	G ¾	80	73.5	- ¹⁾	0.08
45 003 62 901 ²⁾	2	0.2	0.35	35	G ¾	80	73.5	- ¹⁾	0.1
45 009 77 106	3	0.5	-	-	20	98	110	C 75/4	0.3
45 021 77 125	3	2.0	-	-	40	132	120	C 1112	0.5
45 032 77 105	3	3.5	-	-	52	132	152	C 1132	0.65
45 037 77 015	3	4.5	-	-	60	170	175	C 1337	1.1
45 074 77 115	3	8.0	-	-	80	208	185	C 1574	1.3
45 138 77 126	3	15.0	-	-	100	283	200	C 21 138/1	7.0

¹⁾ The filter systems is replaced during maintenance.

²⁾ With integrated pressure control valve.

Fuel filters

Inline filters

For lower requirements regarding filtration our particularly economical small filters are available for installation in flexible hose lines. These filters are especially characterized by relatively high flow rates with small sizes.



Fuel filters

Inline filters from 25 l/h to 90 l/h

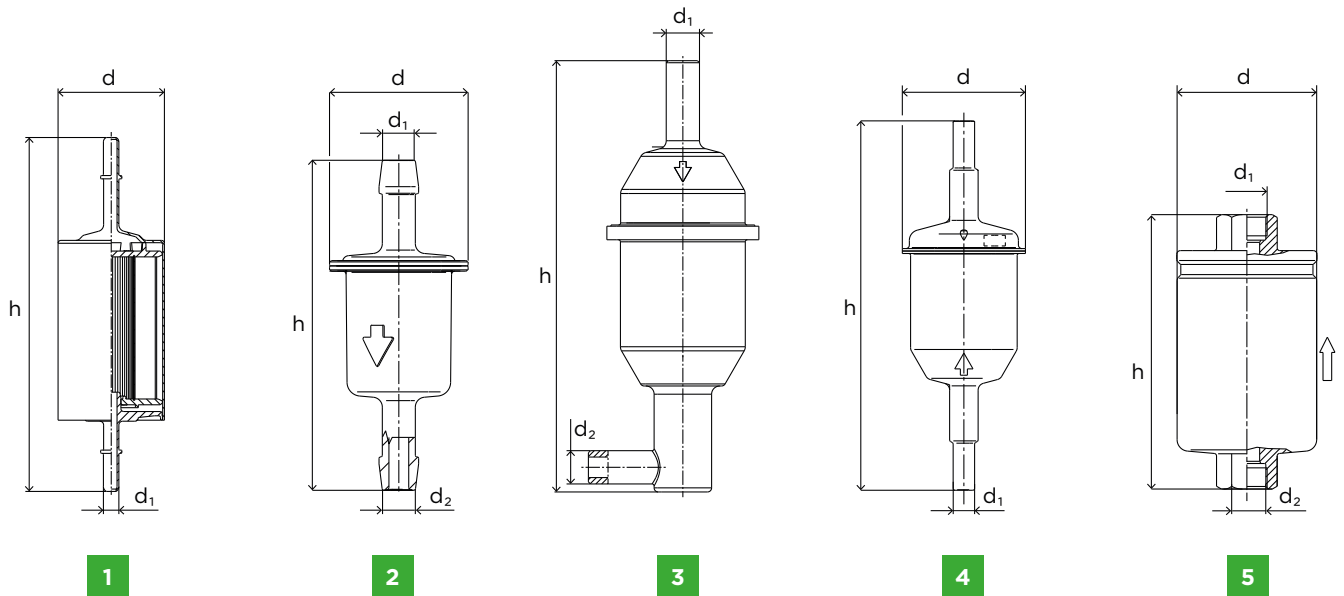

Type	Picture	Volume flow [l/h]	Operating pressure [bar]	Filter unit [mm]		Dimensions [mm]			
				Strainer	Filter medium	d	d ₁	d ₂	h
WK 21	1	25	0.5	50	-	21	6	-	50
WK 21/2	1	25	0.5	136	-	21	6	-	50
WK 31/2	2	40	0.5	-	20	35	6	-	105
WK 31/4	4	50	0.8	200	-	37	8	-	104
WK 31/5	3	50	0.8	200	-	37	8	8	105
WK 42/2	1	30	0.5	-	20	50	8	-	110
WK 43/13	2	40	2.5	200	-	50	-	8	108
WK 612/2	5	90	5.0	200	-	55	M16x1.5	M16x1.5	113
WK 612/5	5	90	5.0	200	-	55	M14x1.5	M14x1.5	113
WK 730/1	1	90	4.0	-	10	81	8	-	172

Fuel filters

Accessories

In addition to our range of proven fuel filters, we offer suitable accessories which were specially developed for our fuel filters. The reliability and long life of these accessories has been proven in numerous applications under extreme conditions.



Fuel filter accessories

PreLine water sensors



Order no.	Picture	Use	Connection thread	Permissible operating temperature	Electrode installation length	Maximum vehicle inclination	Connector description
59 020 70 730	1	PL 50, PL 100, PL 150	M8x1.25	-30 to 100°C	L = 25	-	Junior Power Timer Bosch
59 020 70 732	2	PL 250, PL 150/3X, PL 601, PL 601/1	M12x1.5	-30 to 100°C	L = 27,5	< 30°; signal at 80 ml max. Vol. 150 ml	Junior Power Timer Bosch
10 517 67 S01	3	PL 250, PL 150/3X, PL 601, PL 601/1	M12x1.5	-40 to 110°C	L = 37,0	< 40°; signal at 190 ml max. Vol. 500 ml	DIN 72 585 / ISO 15 170 AMP 1-967 402-2

Further information is available on request.

Fuel filter accessories

Bowl and water discharge



Order no.	Picture	Type	Application	Water collector volume [ml]	Description
66 402 12 321	1	Bowl	PL 150/30, PL 150/31 PL 150/32	180	M12x1.5
66 606 12 949	2	Bowl	PL 270, PL 420	500	Without sensor, including drain plug and seals
21 012 05 341	3	Drain plug	PL 150/30, PL 150/31, PL 150/32, PL 250, PL 271, PL 601	-	-

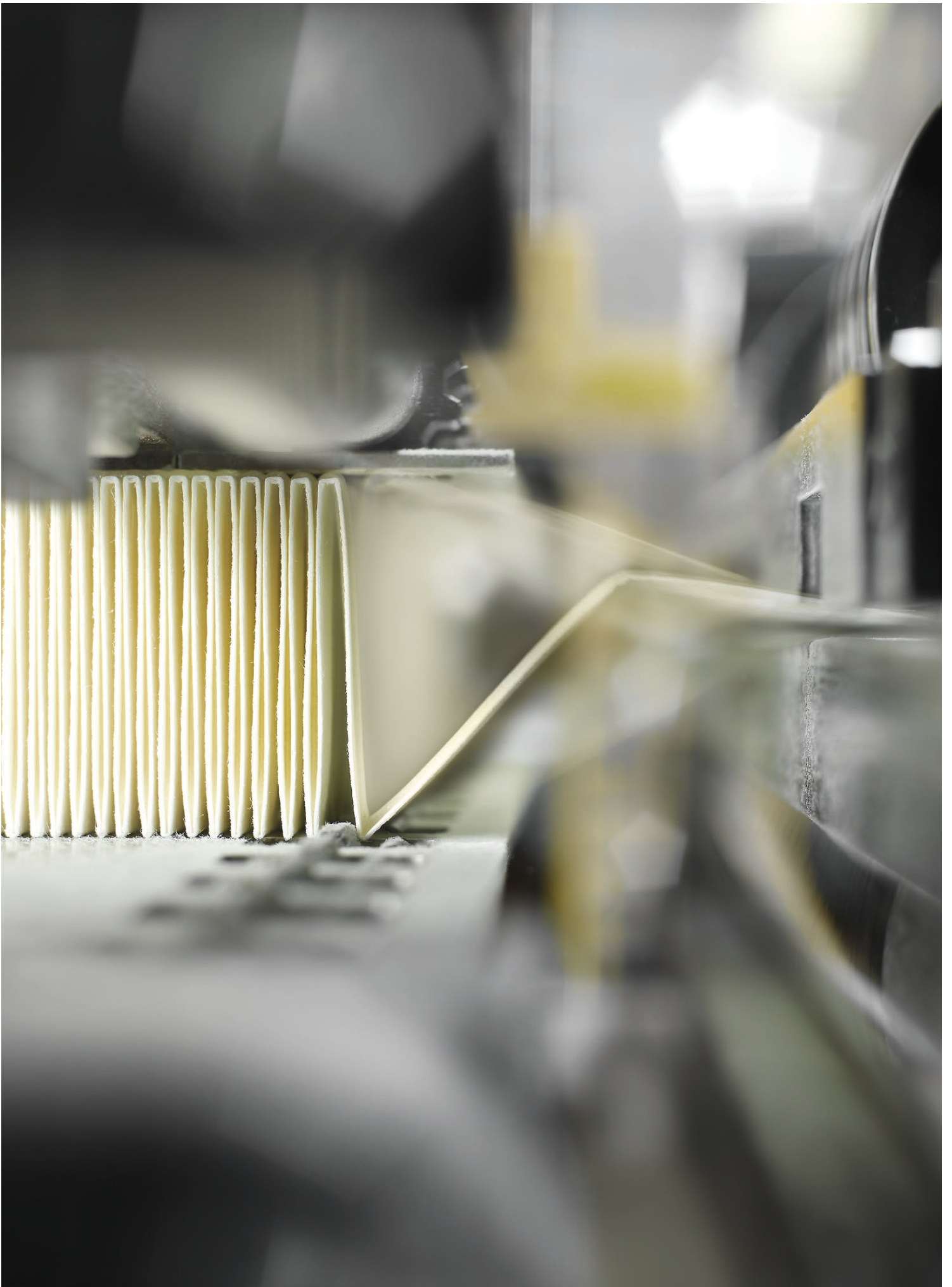

MANN+HUMMEL

Filtration worldwide

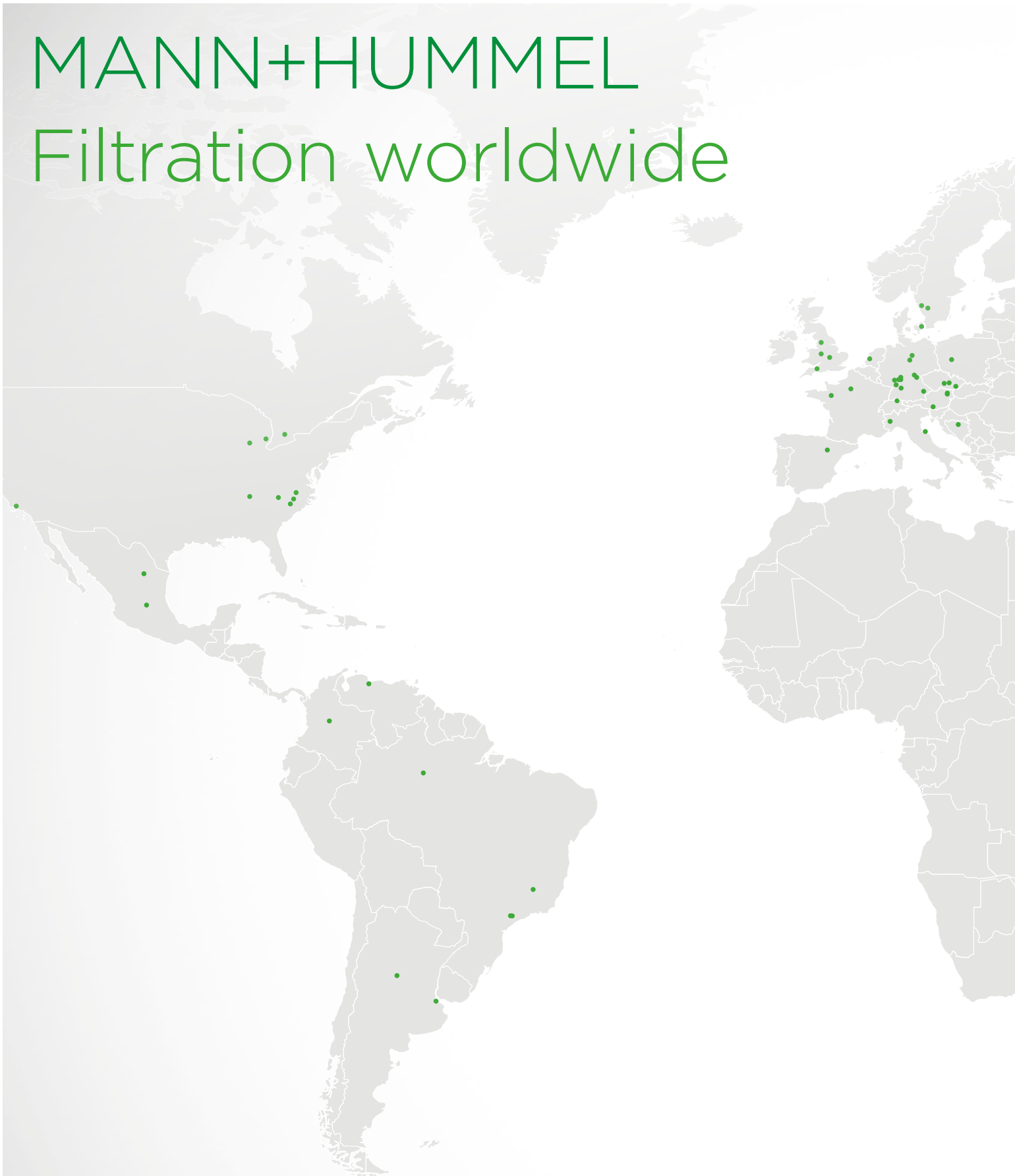

In order to be optimally accessible for you, one of our subsidiaries or a representative is also located near you. Please contact your MANN+HUMMEL contact person or our headquarters if you have any questions or if you require further information.

MANN+HUMMEL Australia Pty Ltd

Phone: +61 (2) 9621 4700

E-Mail: mhau-sales@mann-hummel.com

Website: www.mann-hummel.com

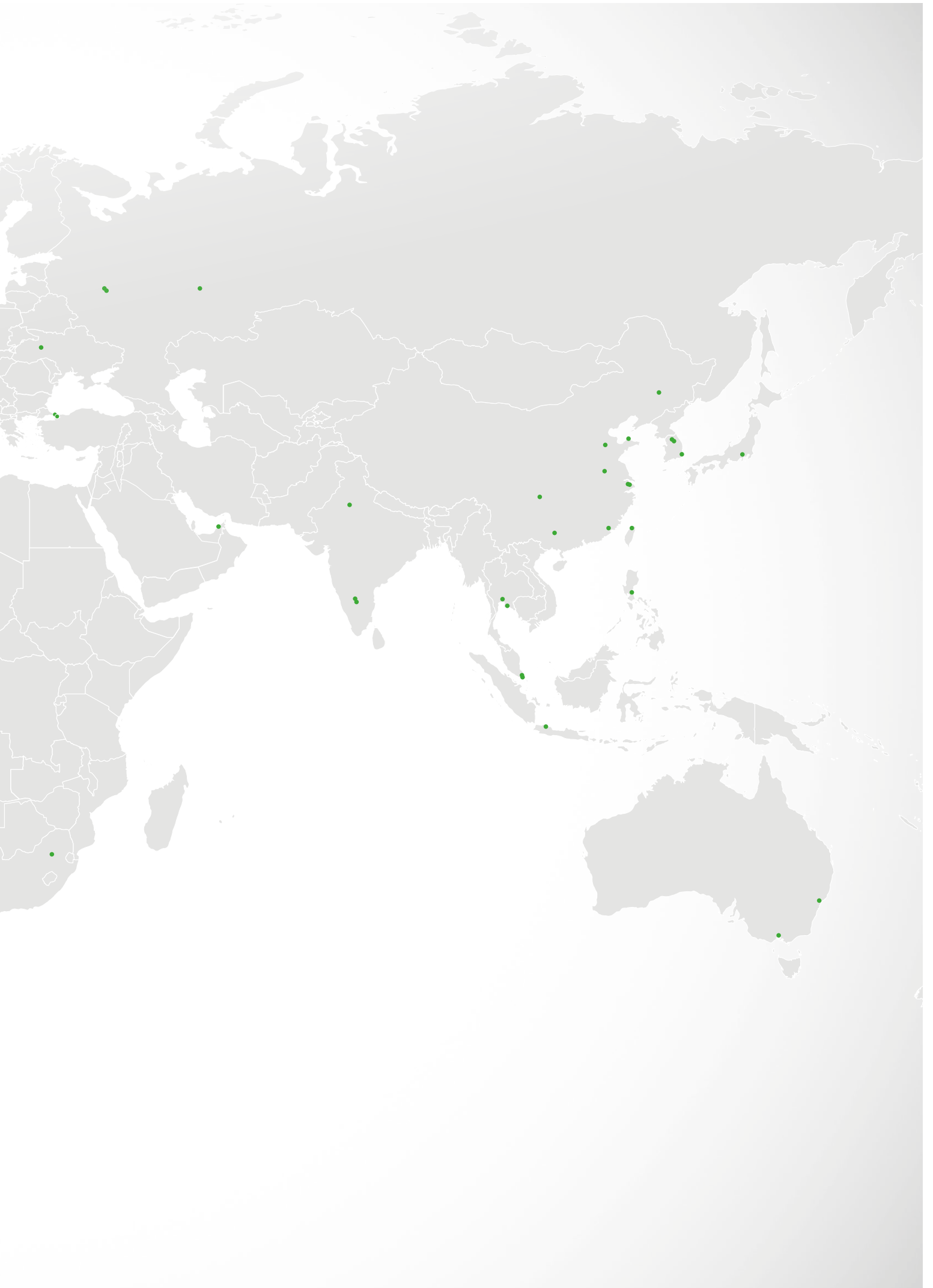



W990000580 EN 1218 Printed in Germany © MANN+HUMMEL GmbH